

# ASSEMBLY INSTRUCTION

TB-O2OMS

20" MINI SIDE TABLE

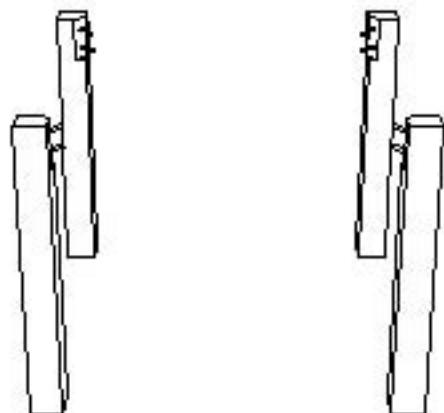

fig 1.

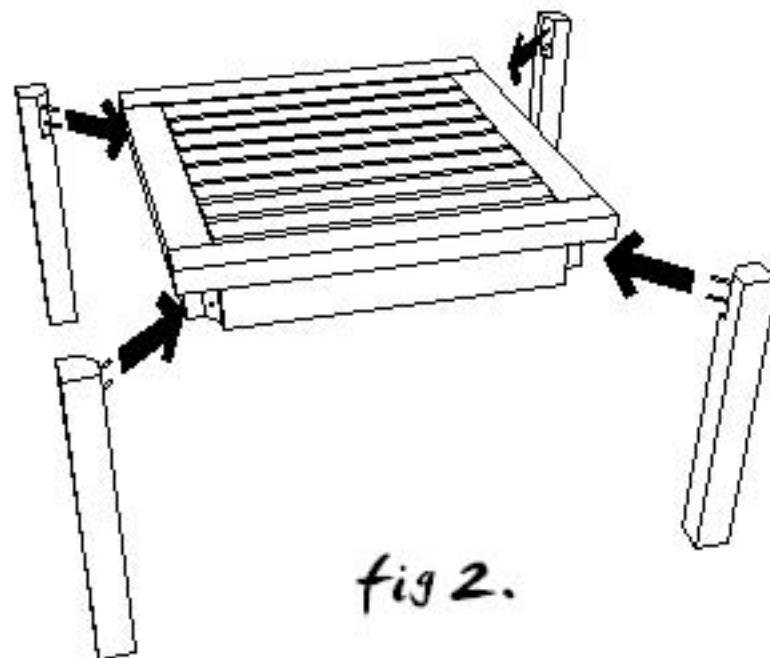

fig 2.

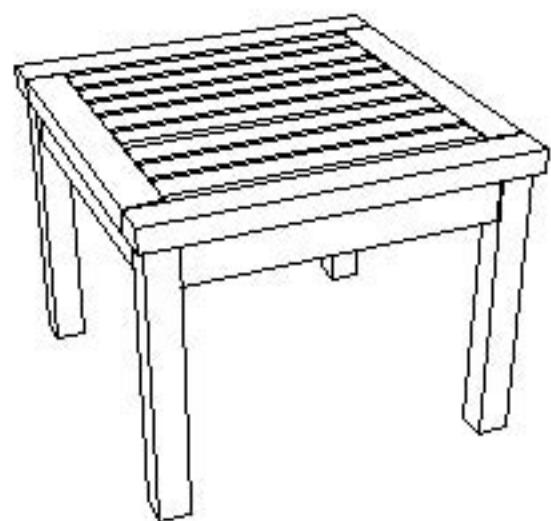

fig 3.

Parts : 4 pcs legs, 1 pc top table

Hardware packs

▶ bolt to clamp the table

Tools requirment

▶ bolt driver ( not supplied )

Assembling

1. Prepare a leg. ( Fig. 1 )
2. Insert the legs into the table. ( Fig. 2 )
3. Tighten the bolt ( under the table ) of the legs.