

ASSEMBLY INSTRUCTION

TBF-O2OR

20" MINI ROUND SIDE FOLDING TABLE

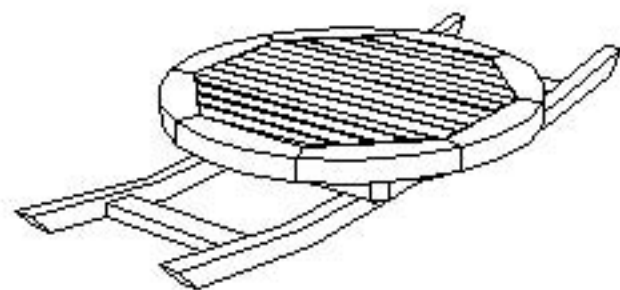

fig 1.



fig 2.

Detail A

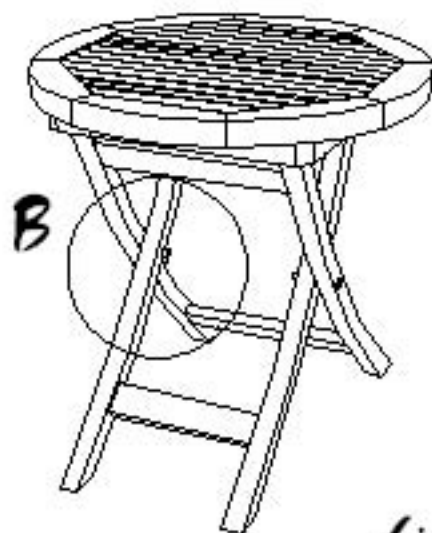
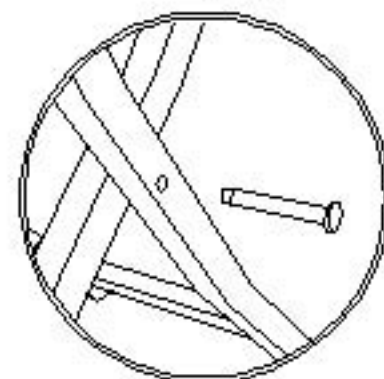
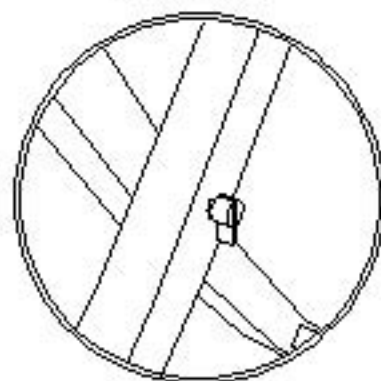

fig 3.

Detail B



Parts : 1 pc table

Hardware packs
▶ brass fittings for legs

Tools requirement : --

Assembling

1. Prepare the table. (Fig. 1)
2. Line the hole together before inserting the brass fitting. (Fig. 2 - Detail A)
3. Bend the edge. (Fig. 3 - Detail B)